

DAISHIN PARTS FEEDER

TF SERIES

●D-30TF ●D-40TF

Model Designation (Example)

D - 30TF - R - 1

- Voltage (1:100V, 2:200V)
- Feed direction (R: clockwise, L: counterclockwise)
- Type of parts feeder
- Name of the manufacturer (Daishin)

Features

The Daishin Parts Feeder TF Series, with the drive magnets arranged on the periphery, are more powerful than the general-purpose feeders (SF series). Also, the spring angle of 15 degrees greatly enhances parts delivery speed and stabilizes delivery with reduced vertical movement.



D-40TF

Dimensional Drawing

●D-30TF

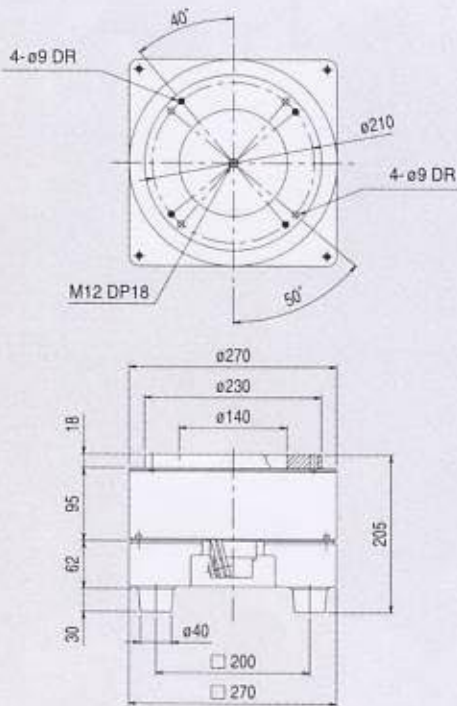

●D-40TF

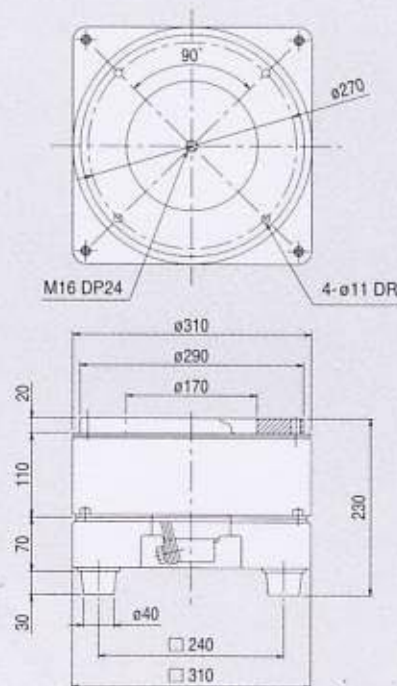

Unit: mm

Specifications

Model	Specification	Weight (kg)	Input voltage (V)	Rated current (A)	Frequency of vibration (times/min)	Applicable bowl diameter	Applicable controller
D-30TF		28.0	100/200	1.6/0.8	6,000~7,200	φ 280~φ 330	IX-01,02/MH-1N
D-40TF		40.0	100/200	2.6/1.3	6,000~7,200	φ 300~φ 400	IX-02,05/MH-1N